

# ENERGIX ADP

## FREE-STANDING AGITATOR DISPERSER

ENERGIX ADP floor-mounted agitators dispersers are machines for low density and low viscosity liquid products mixing, engineered and manufactured to work in difficult industrial conditions. They are sturdy and easy to maintain thanks to high quality and reliable components.



## TECHNICAL FEATURES

- Highly resistant supporting structure in carbon steel with anti-vibration stabilizer reinforcements
- Fixed to the ground with a self-supporting foot
- Electro-welded steel head mounted on ground and chromed guide rods
- Hydraulic lifting by means of an electric pump incorporated in the control unit
- AISI 304 stainless steel mixing shaft
- Ascent stop with mechanical stop and safety device with adjustable valve
- Lenard-type Turbine impeller or AISI 304 stainless steel Cowles-type notched dispersion impeller
- Adjustable impeller height with head gliding during mixing
- Vessel locking system:
  - **fast clamping**, characterized by easy entering of the vessel, fast locking and high resistance to lateral loads. Manual locking clamps with safety micro-contact for machine start only when the container is blocked
  - **adjustable belt**, characterized by a support with adjustable saddles and tensioning ratchet. Possibility of fixing containers with different diameters
  - **double centering arm**, characterized by fork opening of the arms with automatic centering of the vessel under the dispersion impeller while the support saddles facilitate the correct positioning of the vessel. The worm screw with increased thread guarantees an easy opening and closing of the locking. High resistance to lateral loads. Possibility of fixing vessels with different diameters
- Control panel complete with electric buttons, light lamps, speed variation control and tachometer
- Electronic speed variation with inverter
- ATEX version

## ACCESSORIES

- AISI 304 stainless steel Turbo-type toothed impeller
- Motorized lifting group
- Temperatura control probe
- Working cycle timer

## INDUSTRY 4.0 OPTIONAL

- Internal PLC
- Intuitive touch interface for the operator
- Ethernet connections
- Wi-Fi operator control panel
- Router for remote assistance
- Latest generation MISURA software:
  - Preventive maintenance indicators
  - OEE (Overall Equipment Effectiveness) indicators
  - Panel with digital pointers
  - Software interface with customer ERP



# CONFIGURATIONS

Model	Single shaft	Flat lid F for dust and vapor	Flat lid F for dust and vapor with impeller gliding G
Model F	X	X	
Model F-G	X		X

The machine is mainly composed by:

- 1 impeller
- 2 guard
- 3 agitator shaft
- 4 lid
- 5 loading month
- 6 head
- 7 electric motor
- 8 guide columns
- 9 attachment tie-rods
- 10 frame
- 11 electrical system
- 12 lifting piston

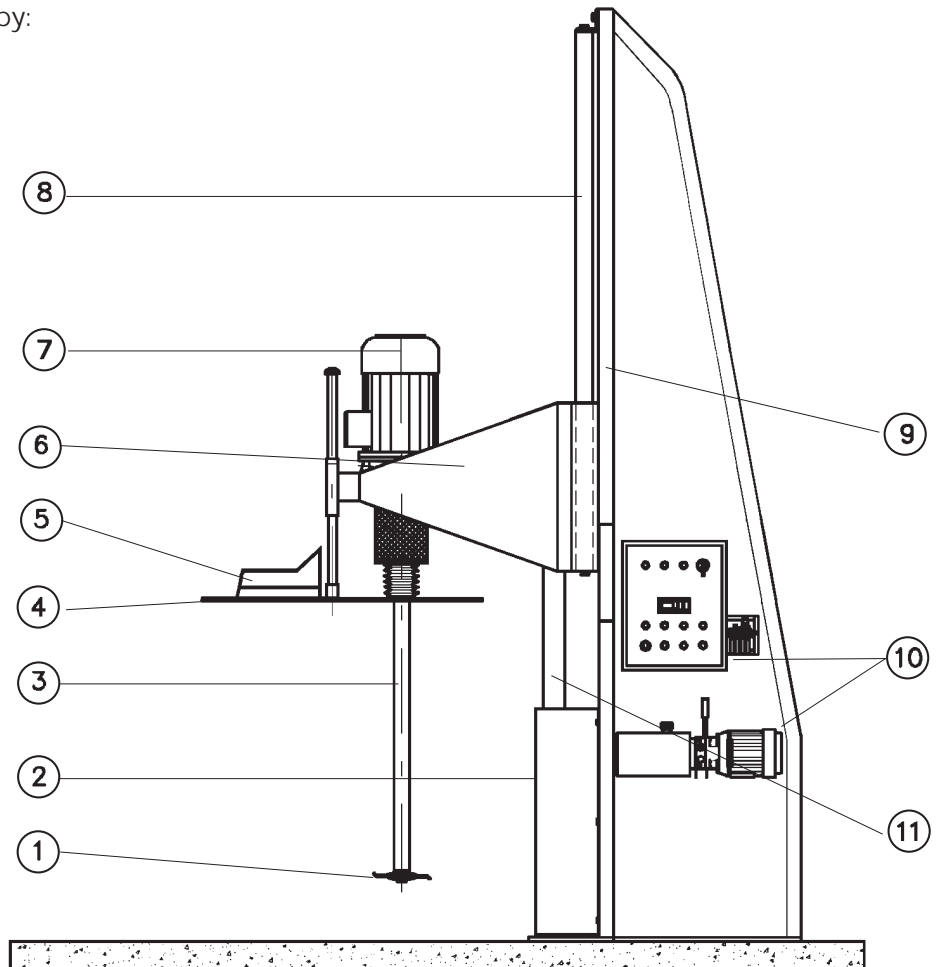

# TECHNICAL DATA

Model	Main motor power		Head lifting motor power		Revolutions per minute	Cowles impeller diameter (mm)	Agitation max. useful volume (lt)	Dispersion max. useful volume (lt)
	Kw	Hp	Kw	Hp				
ADP 5	4	5	1,5	1	0-1450	180	300	100
ADP 7,5	5,5	7,5	1,5	1	0-1450	200	400	130
ADP 10	7,5	10	1,5	1	0-1450	210	700	200
ADP 12,5	10	12,5	1,5	1	0-1450	250	900	250
ADP 15	11	15	1,5	1	0-1450	250	1000	300
ADP 20	15	20	1,5	1	0-1450	270	1200	400

DATA ARE PROVIDED FOR INDICATIVE PURPOSES ONLY

## DIMENSIONS

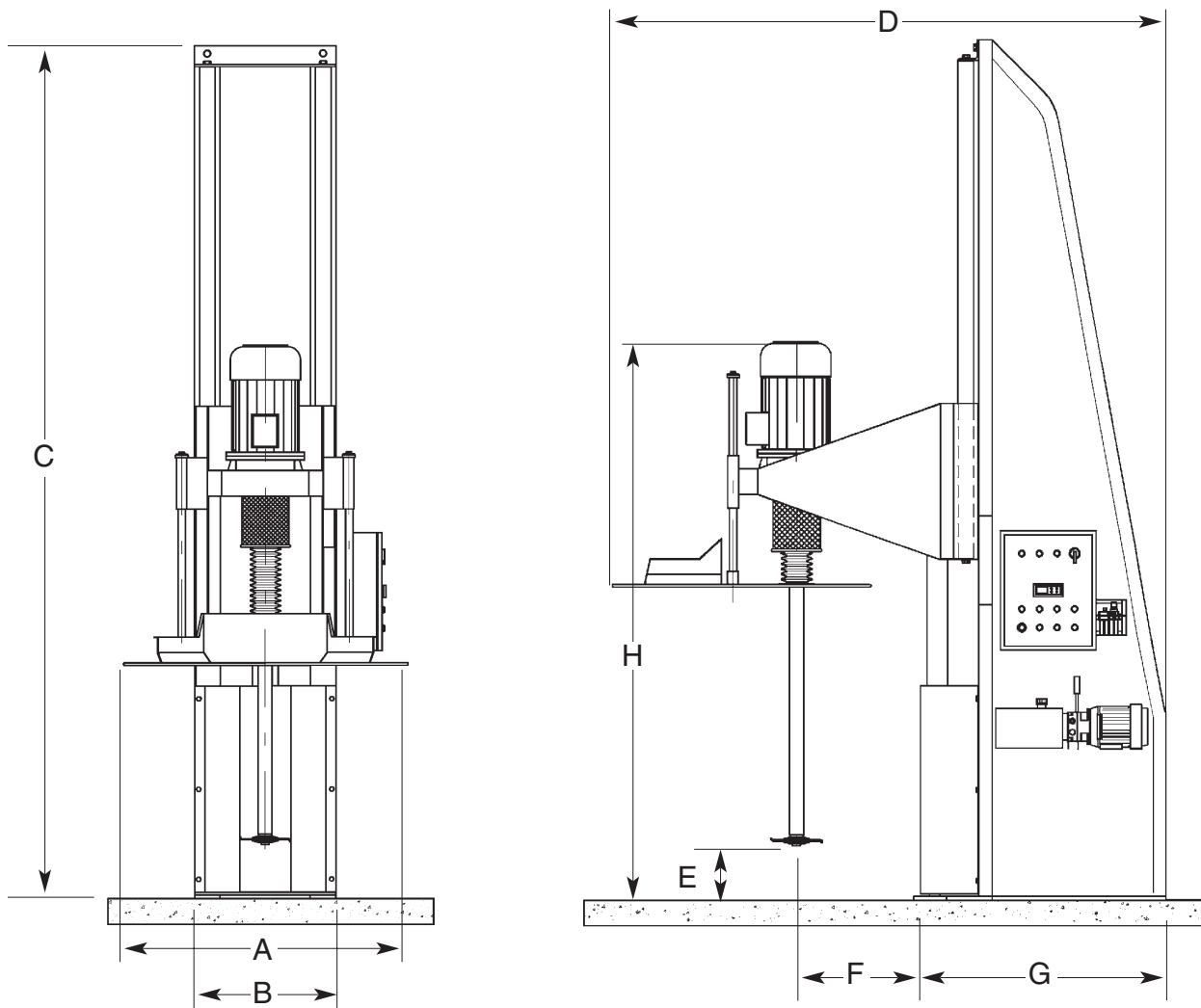

Model	Machine dimensions (mm)							
	A	B	C	D	E (min/max)	F	G	H (min/max)
ADP 5	1100	550	3180	2150	150/1300	475	960	2300/3450
ADP 7,5	1100	550	3180	2150	150/1300	475	960	2300/3450
ADP 10	1100	550	3180	2150	150/1300	475	960	2300/3450
ADP 12,5	1100	550	3180	2150	150/1300	475	960	2300/3450
ADP 15	1100	550	3180	2150	150/1300	475	960	2300/3450
ADP 20	1100	550	3180	2150	150/1300	475	960	2300/3450

## APPLICATIONS

Varnishes, water-based paints, thick coatings, glues, mastics, sealants, cosmetic products, epoxy products, inks, packaging ink, adhesives, plastic materials