

# DYNAMIX DC

## HIGH-SPEED SINGLE SHAFT MOBILE VESSEL DISPERSER

DYNAMIX DC mobile vessel Dispensers are machines for low and medium viscosity products dispersion, engineered and manufactured to work in difficult industrial conditions. Equipped with a high-speed single shaft, also configurable with scraper and in vacuum version, they can meet every production need thanks to a wide range of engines up to 110 kW. This allows to manage products with viscosities from 1,000 Cp up to 300,000 Cp and batches up to 3,000 lt.

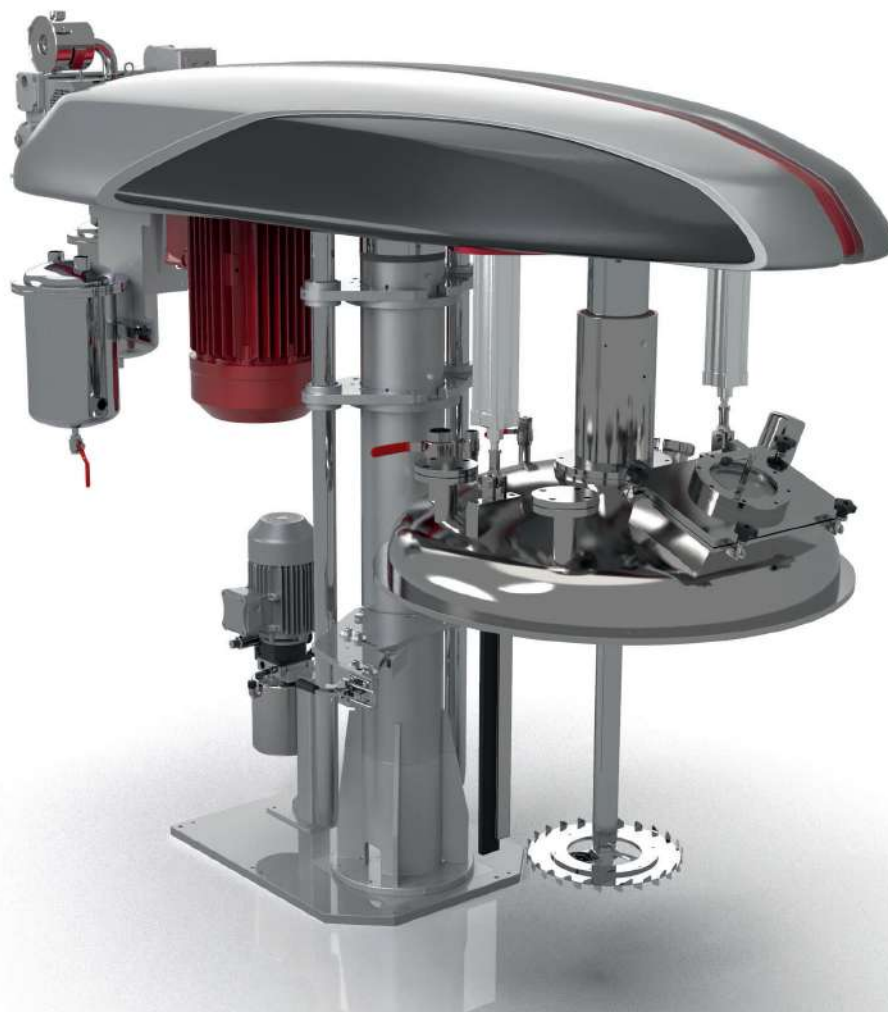

## ADVANTAGES

- Innovative technology enabling INDUSTRY 4.0 that optimizes business processes in terms of management time, costs and quality
- Continuous process control thanks to internal PLC
- Total integration with the production flow and the company ERP
- Efficient recipe management, high product repeatability and reduction of production waste
- Minimization of breakdowns and unwanted downtime by predictive maintenance indicators
- Remote assistance for immediate customer support
- Special design allowing for an easy maintenance of the transmission system

## TECHNICAL FEATURES

- Carbon steel supporting structure with anti-vibration reinforcements
- Rectified and chromed steel telescopic head holder column
- High thickness sheet metal head with anti-vibration reinforcements and pulley protection casings
- Transmission by belt and pulleys
- Hydraulic lifting unit with electric pump embedded in the command group
- Shaft support with high performance ball bearings
- AISI 304 stainless steel high-speed dispersion shaft
- AISI 304 stainless steel Cowles or Turbo type toothed impeller
- Height-adjustable impeller with head gliding during mixing
- Different dust and liquid supply systems integrated in the lid
- Vessel locking system:
  - **Fast Dumping**, characterized by easy entering of the vessel, fast locking and high resistance to lateral loads. Manual locking clamps with safety micro-contact for machine start only when the vessel is blocked
  - **Adjustable Belt**, characterized by a support with adjustable saddles and tensioning ratchet. Possibility of fixing vessels with different diameters
  - **Double Centering Arm**, characterized by fork opening of the arms with automatic centering of the vessel under the dispersion impeller, while the support saddles facilitate the correct positioning of the vessel. The worm screw with increased thread guarantees an easy opening and closing of the locking system. High resistance to lateral loads. Possibility of fixing vessels with different diameters. Possibility of motorizing the opening and closing of the locking system
- Electronic speed variation with inverter
- Also available in ATEX version

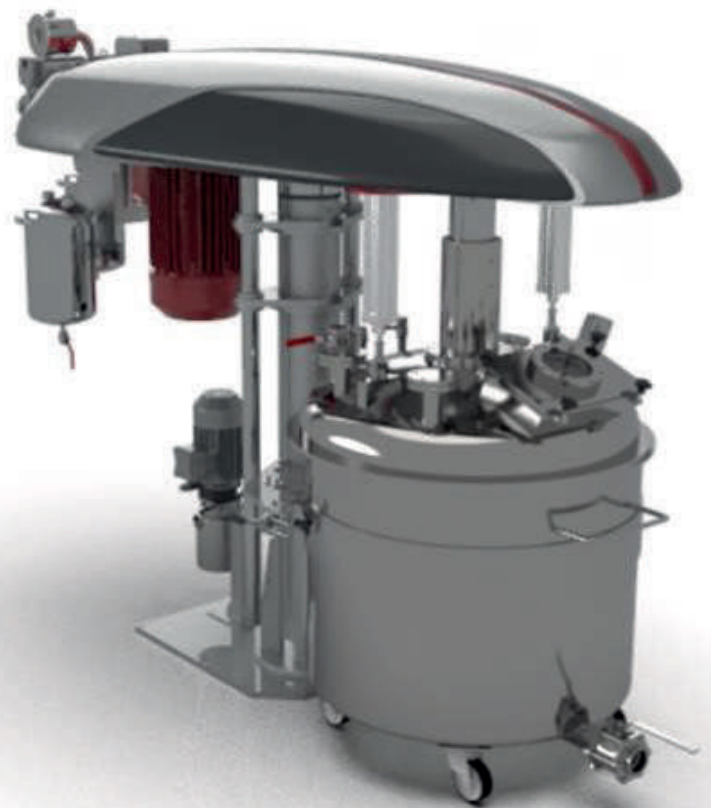

### INDUSTRY 4.0 READY

- Internal PLC
- Intuitive touch interface for the operator
- Ethernet connections

### INDUSTRY 4.0 OPTIONAL

- Wi-Fi operator control panel
- Router for remote assistance
- Latest generation MISURA software
  - Preventive maintenance indicators
  - OEE (Overall Equipment Effectiveness) indicators
  - Panel with digital pointers
  - Software interface with customer ERP

## CONFIGURATION

Model	Single shaft	Single shaft with motorized internal scraper RI	Gliding flat lid G	Gliding lid G rounded for vacuum version SV
F-G Model	X		X	
RI-G Model		X	X	
SV-G Model	X			X
RI-SV-G Model		X		X

## ACCESSORIES

- Motorized internal scraper with opposite movement compared to the dispersion impeller, which can keep the vessel wall constantly clean, conveying the product to the central area even during the disareation phases
- Safety clamps for vacuum version machines
- Lifting column with external fairing
- Vessel with cavities for cooling and external insulation for heating
- Reinforced extruder-ready vessel
- Truncated cone-shaped vessel with reduced capacity
- Servo-ventilated engine for main engine forced cooling
- Product temperature sensor integrated into the shaft
- Level sensor (Encoder)
- Foam sensor
- Safety pressure switch
- Working cycle timer
- Butterfly and ball valves for raw materials loading
- Cup impeller, replacing Cowles impeller, in case of high viscosity and density products with quartz and sand
- Integrated weighing platform system through base with load cells
- Washing system (only in case of a rounded lid with lid-vessel locking clamps):
  - with rotating washing heads fixed on the lid
  - with motorized immersion lance and rotating washing head

## TECHNICAL DATA

Model	Main engine power		Head lifting engine power		Scraper engine power		Vacuum pump engine power		Vacuum pump payload	Revolutions per minute	Impeller diameter (mm)	Maximum useful volume (lt)
	Kw	Hp	Kw	Hp	Kw	Hp	Kw	Hp				
DC - ELE 10	7,5	10	1,5	2	1,1	1,5	1,4	2	40	0-1700	180-200	170
DC - ELE 15	11	15	1,5	2	1,1	1,5	1,4	2	40	0-1700	200-220	230
DC - ELE 20	15	20	1,5	2	1,1	1,5	1,4	2	40	0-1700	220-250	310
DC - ELE 25	18,5	25	1,5	2	1,5	2	1,4	2	40	0-1500	250-270	470
DC - ELE 30	22	30	1,5	2	1,5	2	2	2,7	63	0-1500	270-300	625
DC - ELE 40	30	40	2,2	3	1,5	2	2	2,7	63	0-1500	320-350	850
DC - ELE 50	37	50	2,2	3	1,5	2	2	2,7	63	0-1500	350-380	1000
DC - ELE 60	45	60	2,2	3	2,2	3	2	2,7	63	0-1500	380-400	1200
DC - ELE 75	55	75	2,2	3	2,2	3	2	2,7	63	0-1500	430-450	1500
DC - ELE 100	75	100	3	4	2,2	3	2,7	3,6	100	0-1100	450-500	2000
DC - ELE 125	90	125	3	4	3	4	2,7	3,6	100	0-1100	500-520	2500
DC - ELE 150	110	150	3	4	3	4	5,5	7,4	165	0-1100	520-570	3000

DATA ARE PROVIDED FOR INDICATIVE PURPOSES ONLY



## DIMENSIONS

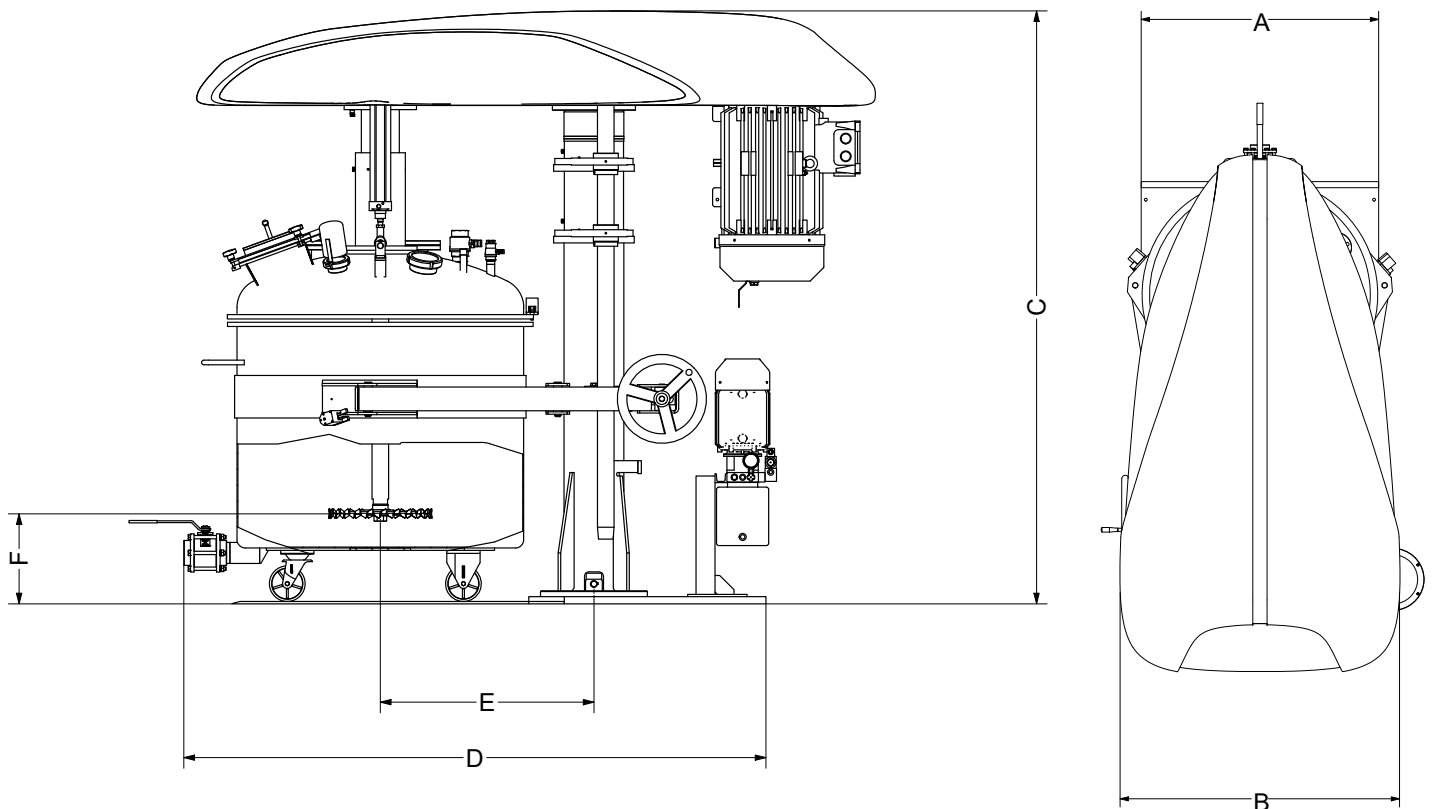

Model	Machine dimensions (mm)					
	A	B	Cmin-Cmax	D	E	F
DC - ELE 10	1000	700	1900 - 2900	2500	650	300
DC - ELE 15	1000	700	1900 - 2900	2500	650	300
DC - ELE 20	1000	700	1900 - 2900	2500	650	300
DC - ELE 25	1200	800	2200 - 3300	2750	650	350
DC - ELE 30	1200	1550	2380 - 3650	2850	950	350
DC - ELE 40	1200	1550	2380 - 3650	2850	950	350
DC - ELE 50	1400	1550	2380 - 3650	2850	950	350
DC - ELE 60	1400	1550	2380 - 3650	2850	950	350
DC - ELE 75	1500	1550	2380 - 3650	2850	950	400
DC - ELE 100	1500	1000	2500 - 3750	3100	1150	400
DC - ELE 125	1700	1000	2700 - 4000	3500	1150	500
DC - ELE 150	1700	1000	2700 - 4000	3500	1150	500

## APPLICATIONS

Paints, water-based paints, thick coatings, glues, putties, sealants, cosmetic products, epoxy products, inks, can coatings, adhesives, plastic materials